

ONE ~ EMBED_ANGLE ~ EM108

BILL OF MATERIAL														FOR FABRICATION			REVISIONS		
ADVANCE MRK	QTY	SHIP MRK	PCS MRK	DESCRIPTION	LENGTH	MATERIAL	REMARKS	ADVANCE MRK	QTY	SHIP MRK	PCS MRK	DESCRIPTION	LENGTH	MATERIAL	REMARKS	DATE	NO.	REVISION/DESCRIPTION	
	1	EM108		EMBED_ANGLE												04/15/23	0	For Fabrication	
	1		EM108	L5X5X5/16	3'-5 1/2"	A36										04/01/2023	A	For Approval	
	3		d103	STUD_3/4-DIA	0'-5 3/16"	A108													
				FIELD BOLTS															
<p style="text-align: center;">FOR FABRICATION</p> <p style="text-align: center;">SHOP NOTES</p> <p>DESIGN DRAWING REF NO: _____</p> <p>E SHEET REF NO: (EMP 102)</p> <p>ALL HEADED STUD SHALL BE AUTO WELDED.</p>																			
SURFACE_PREP: SSPC-SP2				DRY FILM THK. ---		BOLT U.N.O. A325		DRAWN BY:- ANU		DATE:- 04/01/2023									
PAINT: NO PAINT				ELECTRODE :- E70XX		HOLES U.N.O. :- 13/16Ø		CHK'D BY:- VVK		DATE:- 04/01/2023									
PROJECT :- Grace Fellowship Church 201-14-005W Peoria, AZ 85383																			
DESCRIPTION:- EMBED														JOB NO:- --					
CUSTOMER:- --														SHEET # EM108		0			

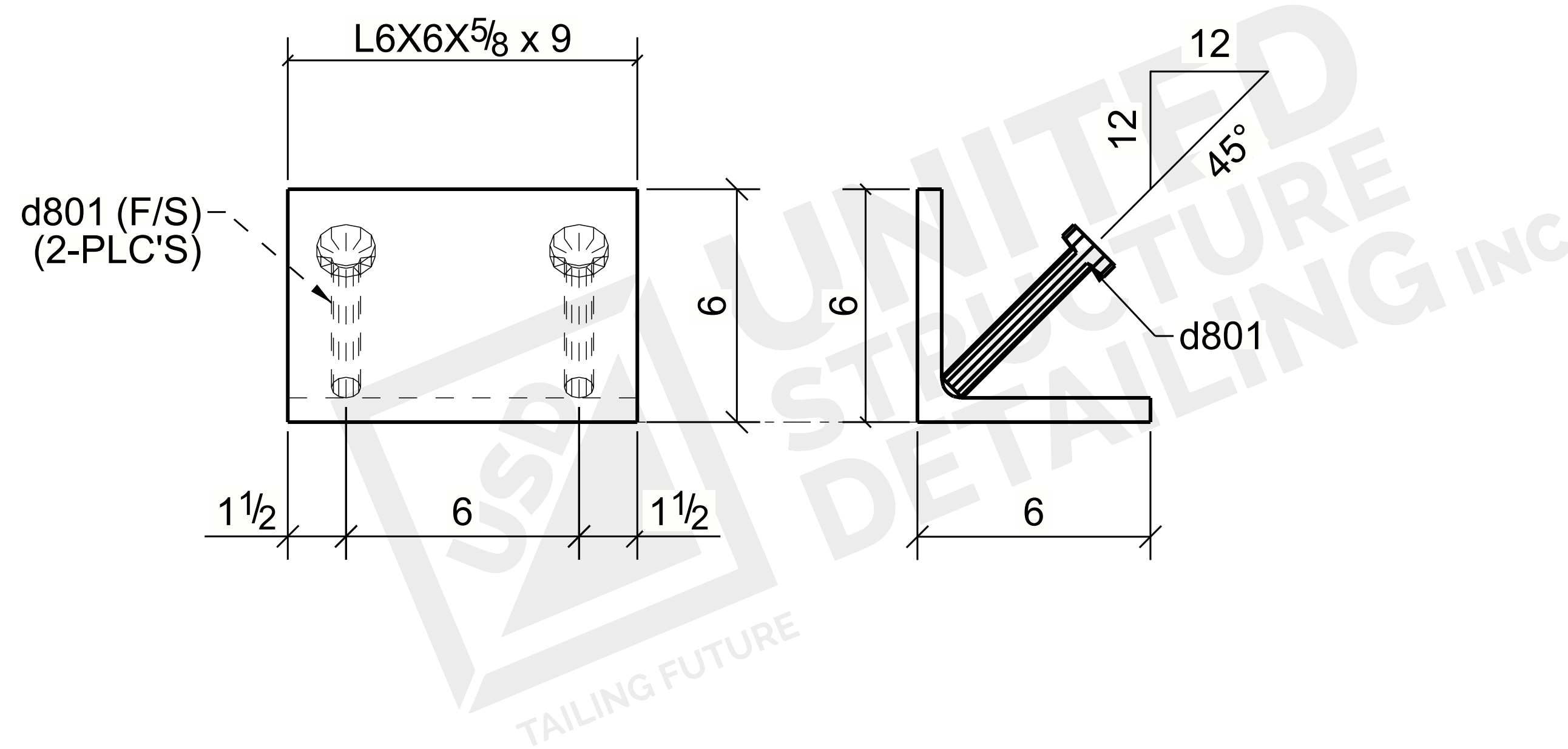

ALL HEADED STUD TO BE AUTO WELDED

12 ~ EMBED ANGLES ~ EM801
(E535 TO E540)

BILL OF MATERIAL

SHIP MARK	PIECE MARK	QTY	DESCRIPTION	LENGTH	REMARKS
EM801		12	EMBED ANGLE		
	EM801	12	L6X6X5/8	0'-9"	
	d801	24	STUD 3/4-DIA	0'-5 3/16"	(A108)
			FIELD BOLTS		

BILL OF MATERIAL

SHIP MARK	PIECE MARK	QTY	DESCRIPTION	LENGTH	REMARKS

FOR FABRICATION

For Fabrication	08/07/2023	
For Approval	03/02/2023	
NO.	DESCRIPTION	DATE

SHOP NOTES

REF. DRAWINGS:	All Pipe: A53-GR.B	U.N.O.
All Material: A36	All Rebar: A706	U.N.O.
All W-Flange: A992	All Headed Studs: A108	U.N.O.
All TS: A500-GR.B	Welds: E70XX	U.N.O.

BLUE PRINTS			BLUE PRINTS			BLUE PRINTS		
NO.	DATE	FOR	NO.	DATE	FOR	NO.	DATE	FOR



ITEM	EMBED	DRAWN BY:	AMI
JOB	SOLANA AT DUARTE STATION	DATE	11/07/2022
LOCATION	1750 FASANA ROAD DUARTE, CA91010	CHECKD BY:	VIK
ARCH.	TCA ARCHITECTS, INC.	DATE	11/07/2022
CONTR.	RD Olson	APPROVED	
ENGR.	SENECA STRUCTURAL ENGINEERING, INC.		
JOB NO.	1420	HOLE SIZE U.N.	13/16Ø
FINISH	NO PAINT	DRWG. NO.	EM801

